

TORQUE MULTIPLIER

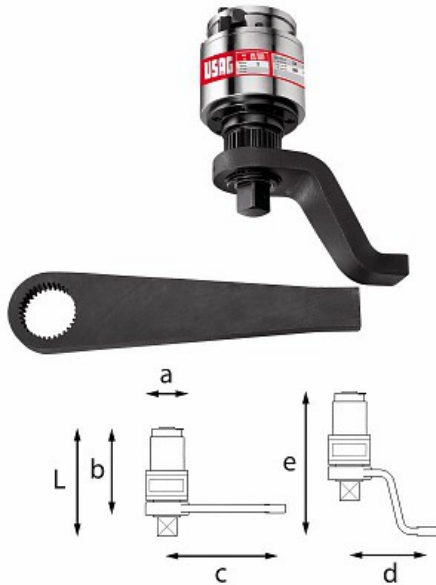

828/6000

- Ratchet model with inversion lever for clockwise and counterclockwise tightening
- Non-return safety system for maintaining multiplier tension, thus avoiding dangerous returns at the end of each tightening operation
- Disengagement device to protect the mechanism which activates when the maximum capacity of the multiplier is exceeded
- Supplied with a fabric bag with straight and offset safety levers and test certificate
- Dimensions (**axbxc**): 119x231x300 mm
- Dimensions (**dxe**): 213x351 mm
- Length (**L**): 271 mm
- Square female: 1/2"
- Square male: 1 1/2"

Family details

Code	Capacity Nm	Multiplication ratio	Transmission ratio	Quantity for packaging
U08280002	6000	27:1	29,752:1	1

Stanley Black & Decker Italia S.r.l.

Sede legale: Via Energy Park 6 - 20871 Vimercate (MB)
 Sede operativa: Via Volta 3 - 21020 Monvalle (VA) Italia
 Partita IVA e C.F.: 03225990138

StanleyBlack&Decker

Società a Socio Unico soggetta a coord. e controllo da parte di Stanley Black & Decker, Inc.
 Capitale Sociale I.V. € 12.000.000